

A FAULT-TOLERANT DISTRIBUTED DATA FLOW ARCHITECTURE FOR REAL-TIME DECENTRALIZED CONTROL

Salvador Fallorina, Paul Thienphrapa, Rodrigo Luna, Vu Khuong,
Helen Boussalis, Charles Liu, Jane Dong, Khosrow Rad, Wing Ho

*Department of Electrical & Computer Engineering, California State University, Los Angeles,
5151 State University Drive, Los Angeles, CA, USA*

Keywords: Distributed data flow, pipelined task mapping, scheduling, fault-tolerance, real-time decentralized control

Abstract: Complex control-oriented structures are inherently multiple input, multiple output systems whose complexities increase significantly with each additional parameter. When precision performance in both space and time is required, these types of applications can be described as real-time systems that demand substantial amounts of computational power in order to function properly. The failure of a subsystem can be viewed as the extreme case of a non-real-time response, so the ability of a system to recognize and recover from faults, and continue operating in at least some degraded mode, is of crucial importance. Furthermore, the issue of fault-tolerance naturally arises because real-time control systems are often placed in mission-critical contexts. Decentralized control techniques, in which multiple lower-order controllers replace a monolithic controller, provide a framework for embedded parallel computing to facilitate the fault-tolerance and high performance of a sophisticated control system.

This paper introduces a fault-tolerant concept to the handling of data flows in multiprocessor environments that are reminiscent of control systems. The design is described in detail and compared against a typical master-slave configuration. A distributed data flow architecture embraces tolerance to processor failures while satisfying real-time constraints, justifying its use over conventional methods. Both master-slave and distributed data flow designs have been studied with regards to a physical control-intensive system; the conclusions indicate a sound design and encourage the further division of computational responsibilities in order to promote fault-tolerance in embedded control processing systems.

1 INTRODUCTION

Fault-tolerance may not be an overriding concern in commodity electronics such as microwave ovens and wristwatches; indeed, the development of reliability features for such items may be an inefficient venture. Fault-tolerance becomes an essential characteristic of systems, however, when the cost of failure is significant. The metrics used to analyze this cost include safety and financial concerns, so continuous uptime is a topic of interest. Additionally the lifetimes of engineering systems are limited by inherent manufacturing defects (Worden & Barton, 2004), but fault-tolerance can provide for graceful degradation, thereby creating a grace period between fully operational and failed states during which failure costs can be minimized.

The research described in this paper has been conducted in the Structures, Pointing, and Control Engineering (SPACE) Laboratory. The National Aeronautics and Space Administration (NASA) provided funding in 1994 to establish the SPACE Laboratory at the California State University, Los Angeles to study the control of complex structures. A major goal of this ongoing project is to develop control systems that exhibit fault-tolerance and real-time response for the James Webb Space Telescope (JWST), which is scheduled for deployment by NASA in the year 2011. As the successor to the currently-active Hubble Space Telescope, a major specification of the JWST is the use of a larger optical mirror to improve upon the quality of images produced by the Hubble. Because there is an apparent difficulty in transporting a single large

mirror in current launch vehicles, the mirror of the JWST will be divided into smaller segments whose overall shape must be dynamically adjusted by an active control system. However, the quality of images collected by the telescope is a function of shaping and pointing precision, among other duties. Therefore the control processing system must maintain a maximal level of fault-tolerance and high performance to maximize the utility of the telescope.

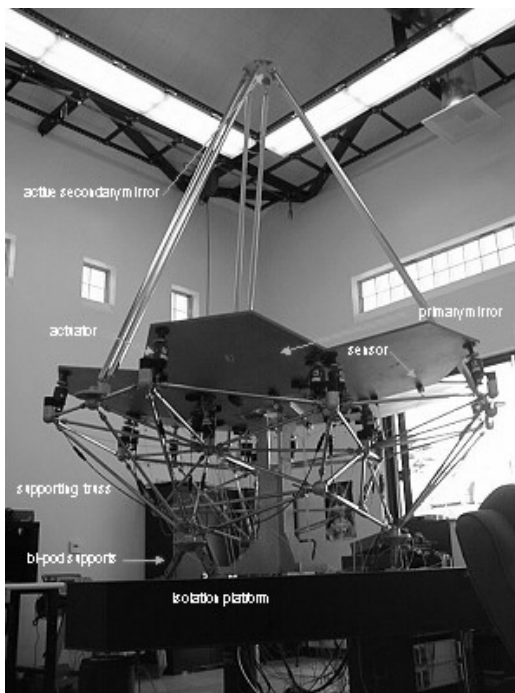

Figure 1: The SPACE testbed.

Specifically, in an embedded multiprocessor platform, the computing system must be able to transparently perform processing tasks while adjusting for the failure and recovery of processors. In the event of processor failure, the computer architecture must be reconfigured so that working processors can assume any data handling responsibilities previously held by failed processors. In a converse manner, reconfiguration must be performed when processors are recovered in order to minimize the reliance of the system on any single processor. By establishing mechanisms for fault-tolerance, real-time performance can be realized even when processor failures occur.

This paper is organized as follows. A description of the SPACE testbed, on which research for this project is conducted, is given in Section 2. Section 3 details the theoretical foundations for decentralized control of the system. In Section 4, control processing from the perspective of the computing system is described. Section 5 presents the data flow

architectures under consideration, while Section 6 proposes a design that utilizes the novel data flow mechanism to achieve processor fault-tolerance in real-time decentralized control. Concluding remarks are provided in Section 7 along with future plans.

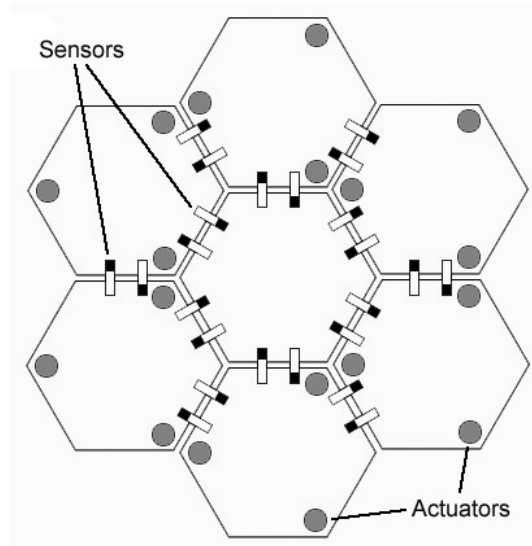

Figure 2: SPACE testbed primary mirror.

2 SYSTEM DESCRIPTION

2.1 Peripheral Structure

The SPACE testbed, pictured in Figure 1, resembles a Cassegrain telescope with a 2.4m focal length. Its performance is designed to emulate an actual spaceborne system (Stockman, 1997). As mentioned above, the large optical mirror of the JWST will be segmented so as to allow for conveyance via contemporary launch vehicles. Figure 2 illustrates the segmented mirror configuration present on the SPACE testbed. A ring of six actively-controlled hexagonal panels is arranged around a fixed central panel. Three voice-coil linear actuators are mounted to the underside of each panel, providing each with three degrees of freedom. Twenty-four inductive sensors are placed at the panel edges to provide measurements of relative displacements and angles. During control calculations these 24 sensors are geometrically virtualized into 18 sensors, in accordance with the arrangement of the actuators, for implementation convenience. The actuators and sensors are linked to the digital control processing system respectively via digital-to-analog (DAC) and analog-to-digital converters (ADC).

2.2 Embedded Computing System

The SPACE testbed processing system is configured with four 32-bit TMS320C40 digital signal processors. These processors feature a 40ns cycle time and 30 MIPS/60 MFLOPS maximum ratings. Each processor has 1 MB of local memory and access to 1 MB of global memory (Figure 3). High-speed, bidirectional, half-duplex communication ports provide a maximum of 20 MB/s message passing throughput amongst processors. Using a VMEbus interface with a VIC64 chip acting as a bus arbiter, each of the four processors has direct access to the sensor input channels (ADC) and the actuator output channels (DAC), giving rise to a myriad of possible data flow configurations.

As an important note, the computing architecture for the SPACE project is fixed. Therefore all attempts at high performance and fault-tolerance must be based on the existing hardware.

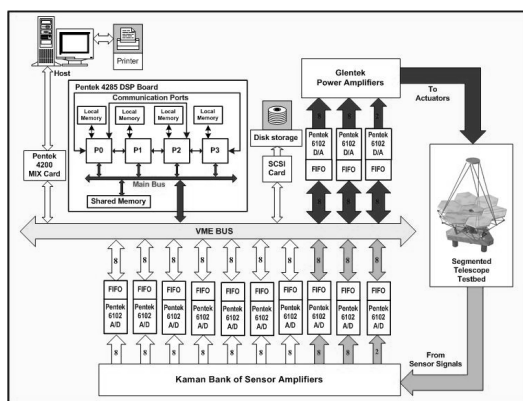

Figure 3: SPACE testbed computing system.

2.3 Performance Requirements

To achieve the intended performance goals, any algorithm designed for this control application must complete computations in 0.8-1.6 ms per sample; that is, using a sampling rate of 20-40 times the system bandwidth of 30 Hz (Boussalis, 1994). This specification, coupled with the structural complexity of the telescope, attests to the real-time computational requirements. Because sporadic failure of processors to meet this time restriction is of minor consequence, this application fits the soft real-time systems category; however, prolonged non-real-time performance will result in the degradation of the quality of images collected by the telescope.

3 DECENTRALIZED CONTROL FOR THE TESTBED

Control of sizeable structures is an ongoing topic of interest in space exploration programs. As described previously, the SPACE testbed consists of a large number of structural components whose behavior is guided by a complement of sensors and actuators, leading to mathematical models that involve hundreds of states. Even after the application of classical model reduction techniques, a centralized control model of the telescope testbed has over 200 states complementing 18 virtual sensors and 18 actuators. Consequently, the design of control laws based on conventional methodologies becomes exceedingly unwieldy. Decentralized control then becomes an increasingly attractive approach in circumventing this difficulty concerning the dimensionality problem.

Due to the complex nature of the SPACE testbed, decentralized techniques are employed for the development of simplified laws to accomplish reflector shape control. The result is the physical decentralization of the structure into six lower-order subsystems.

The system equations of motion assume the form

$$M \ddot{\underline{\delta}} + K \underline{\delta} = B_1 \underline{u} + B_2 \underline{d}. \quad (1)$$

M refers to the mass matrix, and K the stiffness matrix, while $\underline{\delta}$ is a position coordinate vector, B_1 and B_2 are force amplitude matrices, \underline{u} is a control-input vector and \underline{d} is a disturbance vector. For control purposes the following state-space representation of the system is derived from (1).

$$\begin{aligned} \dot{x} &= Ax + Bu \\ y &= Cx \end{aligned} \quad (2)$$

Decomposing the system (2) into six subsystems according to the physical structure depicted in Figure 2 yields (3) as follows.

$$\begin{aligned} \dot{x}_i &= A_{ii}x_i + \sum_{i=1}^6 A_{ii}x_i + B_{1i}u_i + B_{2i}d \\ y_i &= C_i x_i \end{aligned} \quad (3)$$

The first term of (3) is its isolated component.

$$\dot{x}_i = A_i x_i, \quad (4)$$

$$x_i = \begin{bmatrix} \delta_i^T & \dot{\delta}_i^T \end{bmatrix} \quad (5)$$

As shown in Figure 4, the system is naturally decentralized by treating each of the six peripheral segments of the primary mirror and its associated supporting structure as an isolated subsystem. Each decentralized controller can be of arbitrary type, as hinted in the figure; an H_∞ controller is typically used for testing. Each subsystem is identified by three control inputs to the actuators and three control outputs which are measured by the edge sensors. Note that the definitions of inputs and outputs are context-sensitive. The sensor signals are outputs of the *control system*, but are inputs to the *computing system*. A similar situation exists with regards to actuator signals. Local control algorithms are developed for each of the six isolated subsystems.

We consider discrete control algorithms. The state-space form embodied in (2) is translated to the discrete form shown in (6).

$$\begin{aligned} x_{n \times 1}(k+1) &= \Phi_{n \times n} x_{n \times 1}(k) + \Psi_{n \times m} u_{m \times 1}(k) \\ y_{r \times 1}(k) &= C_{r \times n} x_{n \times 1}(k) \end{aligned} \quad (6)$$

This discrete state equation represents an n^{th} -order system with m inputs and r outputs (from a computing systems perspective), where Φ is the state transition matrix, $x(k)$ is the state vector, $u(k)$ is the vector of sensor signals, and $y(k)$ is the actuator signal vector. In implementing decentralized control for the testbed, a single 200th-order centralized controller is replaced by six 12th-order local controllers that run in parallel to maintain the precise shape of the primary mirror. Such a replacement reduces the computational complexity of the control system, and exposes opportunities for both parallel processing and fault-tolerance. The control calculations for each of the six subsystems are given below with $n = 12$, $m = 3$, and $r = 3$.

$$\begin{aligned} x(k+1) &= \Phi \times x(k) + \Psi \times e(k) \\ u(k) &= C \times x(k) + D \times e(k) \end{aligned} \quad (7)$$

4 CONTROL PROCESS DESCRIPTION

Given the nature of digital systems, control computations are performed in discrete cycles, and sensor readings are sampled accordingly. A control cycle begins when processors read sensor signals from the ADC and geometrically transform them into virtual points that indicate the displacement and positions of the panels. The next step consists of calculating control commands for the six subsystems. A single *control task* involves the

control calculations for a single subsystem, given in (7). Resultant control signals are written to the DAC, amplified, and sent to the actuators to properly reposition the panels. As mentioned, these steps must be executed continuously and within a specified sampling period in order to ensure quality shaping and system stability.

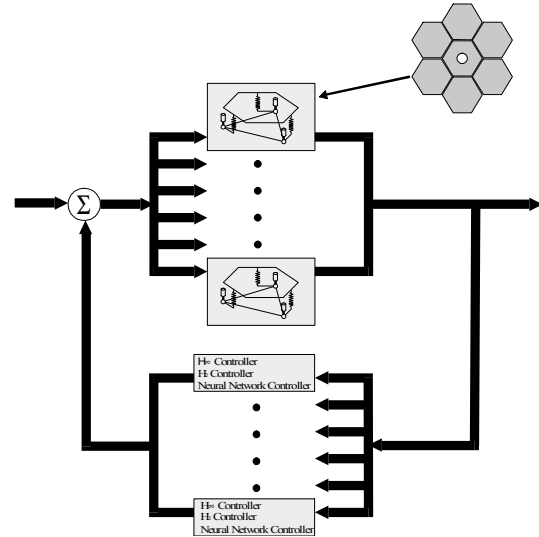

Figure 4: Decentralized control system block diagram.

Sequential execution of control tasks using a single processor is possible, but the disadvantages that arise include extended execution time and lack of fault-tolerance. Decentralized controllers present opportunities for parallel execution during a control cycle. Parallel processing is thus applied in order to achieve fault-tolerance and real-time performance. Based on our model of decentralized control, $M = 6$ tasks are executed in parallel among $P = 4$ processors in an iterative fashion.

Whether they are scheduled for execution on processors in a straightforward, pipelined (Fallorina, 2004, Thienphrapa, 2004), group-pipelined (Roberts, 2004) (see Figure 5), or other fashion, control tasks must satisfy the following characteristics in order for this application of decentralized control to work.

1. Each task is not further decomposable.
2. The computational complexities of all tasks are identical.
3. Each task must complete a control cycle and cannot be scheduled until its sample of sensor signals is obtained.
4. There is no data dependency among the computational tasks, so different tasks can be processed in different control cycles in an arbitrary order.

The computational dependence between the subsystems is negligible. Thus the six panels of the primary mirror do not need to cooperate with each other to achieve precision shaping because local controllers perform the alignment against a calibrated parabolic reference. Note that for a processor to process any number of tasks (Figure 5), it must have access to the corresponding sample of sensor signals, the current state vectors, and a means of sending the actuator output signals to the DAC. Therefore the design of fault-tolerant data flow architectures is of utmost importance.

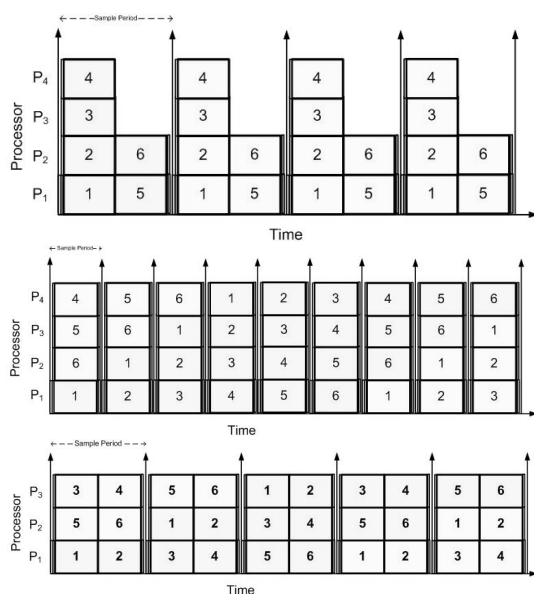

Figure 5: From top to bottom, straightforward, pipelined, and group-pipelined task scheduling.

5 DATA FLOW ARCHITECTURE

In order to ensure continuous control of the telescope testbed, an efficient and reliable data flow architecture needs to be in place that gives each processor the full set of sensor data.

5.1 Master-slave Data Flow System

One conventional approach structures the flow of data in a master-slave configuration (Figure 6). In this method, only one processor, the master, handles all the data inputs and outputs. The master processor reads all data from the ADC first-in, first-out (FIFO) buffers and passes them to each of the slave processors. Once each processor finishes the control computations, the results are passed back and gathered by the master processor, which then proceeds to send the control commands to the plant.

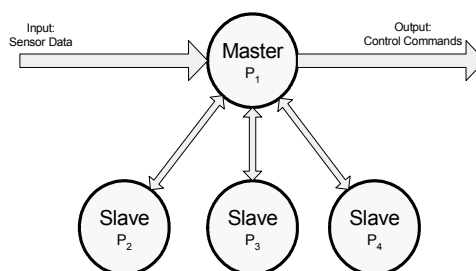

Figure 6: Master-slave data flow.

This arrangement is simple and straightforward, but relies on a single processor. The system can be made to tolerate any slave processor failure, but in the event the master processor fails, then the entire computing system fails.

5.2 Distributed Data Flow System

The proposed distributed data flow architecture detailed here describes the development of a symmetric computer architecture where all processors operate identically. In this distributed data flow architecture (Figure 7), all processing nodes are capable of handling any input and output of data. In other words, each processor can read sensor signals from the ADC buffers independent of other processors, then perform its subset of the decentralized control calculations (this subset, i.e. task(s), is assigned based on the task mapping mechanism in use (Fallorina, 2004, Thienphrapa, 2004, Roberts, 2004)). Upon completing its calculations, each processor can then independently send the results to the plant to command the appropriate actuators.

5.3 Comparison

This distributed scheme is more compatible with the concept of decentralized control and facilitates fault-tolerance by removing the reliance of the system on any single processor. If one or more processors fail or recover from failure, the architecture is able to accommodate for these events and resume normal operations transparently. This is the distinguishing advantage of the distributed system over the master-slave configuration. Failure of the master processor would lead to immediate failure of an entire master-slave computing system.

In light of this observation, what warrants discussion of the master-slave architecture is its widespread use in situations where failure is not a pressing concern (e.g. desktop computers), as well as its ease of implementation. Specifically, the distributed data flow architecture introduces

synchronization issues; processors must be synchronized within a control cycle in order for task scheduling to transpire correctly. Correctly implementing this mechanism with synchronization is nontrivial. Such matters can play a role in the development costs, development time, and reliability of the end product.

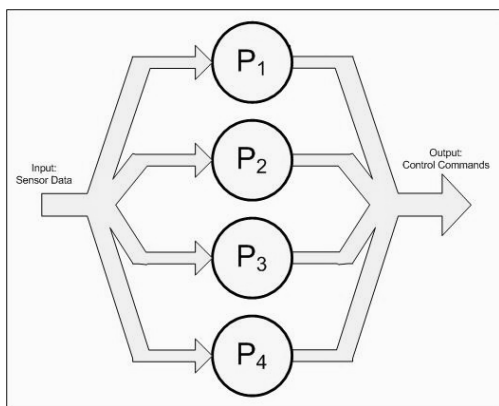

Figure 7: Distributed data flow.

5.4 Limitations

Although several works in high performance, fault-tolerant computing were considered, they were discounted due to the fixed, specialized nature of the SPACE testbed.

For instance, hardware and software redundancy described in the literature (Reinhardt, 2000, Khan 2001) are not feasible due to rigid power constraints. Other approaches assume workstation environments (Baratloo, 1995, DasGupta, 1999) that do not exhibit real-time performance. Due to hardware limitations, reconfigurable circuits (Blanton, 1998) and proactive fault detection (Siewiorek, 2004) cannot be used. Fortunately, the control process is straightforward and does not require sophisticated task mapping (Choudhary, 1994).

6 DATA FLOW DESIGN

In applying the distributed data flow architecture to the SPACE testbed computing system, various challenges arise due to its physically centralized data bus (Figure 8). Firstly, given the system architecture and hardware capabilities and limitations, the implementation of this design method requires more communication. Sensor data is located in destructive-read FIFO buffers on different ADC boards (Figure 8). Therefore, any data read by a processor is removed from the corresponding buffer space. If such data is required by the other

processors, point-to-point communication between the processors will be necessary. Another practicality is that VMEbus accesses must be time-shared amongst processors. In addition, task mapping becomes complicated when integrated with pipelined task scheduling techniques (Fallorina, 2004, Thienphrapa, 2004, Roberts, 2004).

To implement this distributed data flow architecture, each processor reads a subset of the total data and distributes the data amongst each other. This is achieved by configuring the ADC boards to send interrupt signals to assigned processors which read data from the interrupt source. Each time a processor takes data from the ADC FIFO buffers, it writes that data to shared memory where any other node can access it. This step is necessary because the full set of sensor samples is generally required to process control commands for any subsystem task. Future work will address the effects of using only a subset of these samples. In the end, all of the data is made equally available to any processor, producing the logical effect of distributed data flow.

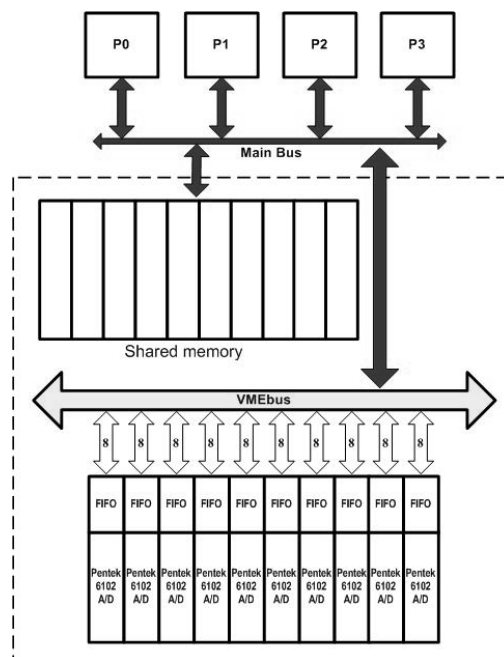

Figure 8: Distributed data flow on the SPACE testbed.

The architecture of the system board and the VMEbus connection to the processors are not conducive to perfect fault tolerance. There are several bottlenecks in the architecture that do not have redundancies. However, an abstraction is created that allows for the design of fault tolerance that bypasses hardware limitations. Furthermore, an implementation will demonstrate proof-of-concept

that the proposed solution does indeed support fault-tolerant real-time decentralized control.

Although fault detection is a rich area of interest in its own right, it is briefly discussed here as it pertains to the SPACE testbed. The shared memory, message passing, and interprocessor interrupt resources can be used to construct various fault-tolerance mechanisms. Already considered ideas include using watchdog, neighbor, and ad hoc detection methods to indicate the state of processors.

Reconfiguration for faults and recovery must be efficient in real-time systems. Pipelined task mapping performs this reconfiguration at the control task level by dynamically assigning tasks based on the working state of processors. At the data flow level, working processors can assume the data handling duties of failed processors in a state machine-like fashion. That is, the sensor and actuator channels that processors access will be determined by the quantity and identities of the processors that are failed. The mechanical attribute of such an approach will foster efficiency.

7 SUMMARY & FUTURE WORK

Costly and mission-critical systems must exhibit fault-tolerance in order to minimize loss due to failure. One facet of fault-tolerance provides for a grace period between fully functional and nonfunctional states during which steps can be taken to prepare for ultimate failure. More central to this project, however, is the uptime. It is desirable for a space telescope to smoothly continue operation despite the failure of processors on a multiprocessor platform, which is a single-event upset in nature and is a likely occurrence given the operating environment. With tolerance for processor failure enabled, a telescope can perform its scientific and logistical duties with minimal downtime.

The distributed data flow architecture proposed here has been conceived for fault-tolerant, real-time decentralized control of a segmented reflector telescope testbed. In contrast with a master-slave configuration that has already been implemented, this approach does not rely on a single processor because the data input-output can be handled by any processor. This arrangement facilitates continuous system operation despite any processor failure. Future work includes completion of the distributed data flow architecture, detection and reconfiguration. Various fault detection and reconfiguration schemes will be tested and analyzed in addition to issues of sensor, actuator, and signal converter failure.

8 ACKNOWLEDGEMENTS

This work was supported by NASA under Grant URC NCC 4158. Special thanks go to all the faculty and students associated with the SPACE Laboratory.

9 REFERENCES

- Baratloo, A. et al. 1995, 'CALYPSO: a novel software system for fault-tolerant parallel processing on distributed platforms', *Proc. IEEE HPDC*, PC, VA.
- Blanton, R., Goldstein, S., & Schmidt, H. 1998, 'Tunable fault tolerance via test and reconfiguration', *Proc. FTCS*, Munich, Germany.
- Boussalis, H. 1979, *Stability of Large Scale Systems*. Ph.D. dissertation, New Mexico State University.
- Boussalis, H. 1994, 'Decentralization of large space-borne telescopes', *Proc. SPIE Symposium on Astronomical Telescopes*.
- Choudhary, A. et al. 1994, 'Optimal processor assignment for a class of pipelined computations', *IEEE Transactions on Parallel and Distributed Systems*, vol. 5, no. 4, pp. 439-445.
- DasGupta, B. et al. 1999, 'Generalized approach towards the fault diagnosis in any arbitrarily connected network', *Proc. HiPC*, Calcutta, India.
- Fallorina, S. et al. 2004, 'A generic pipelined task scheduling algorithm for fault-tolerant decentralized control of a segmented telescope testbed', *Proc. ASME DETC/CIE*, Salt Lake City, UT.
- Khan, G., & Wee, S. 2001, 'Fault-tolerant embedded computer system-on-chip for endoscope control', *Proc. ISIC*, Singapore.
- Reinhardt, S. & Mukherjee, S. 2000, 'Transient fault detection via simultaneous multithreading', *Proc. ISCA*, Vancouver, BC.
- Roberts, J. et al. 2004, 'Efficient real-time parallel signal processing for decentralized control using group-pipelined scheduling', *Proc. ISNG*, Las Vegas, NV.
- Siewiorek, D. et al. 2004, 'Experimental research in dependable computing at Carnegie Mellon University', *Proc. WCC*, Toulouse, France.
- Stockman, H. et al. 1997, *The Next Generation Space Telescope: Visiting a Time When Galaxies Were Young*, The Association of Universities for Research in Astronomy, Baltimore, MD.
- Thienphrapa, P. et al. 2004, 'A generalized fault-tolerant pipelined task scheduling for decentralized control of large segmented systems', *Proc. CCCT*, Austin, TX.
- Worden, K. & Dulieu-Barton, J.M. 2004, 'An overview of intelligent fault detection in systems and structures', *Structural Health Monitoring*, vol. 3, no. 1, pp. 85-98.